



LNL (Cambodia) Co., Ltd.

House No.14, Street No,02A, Sangkat Teuk Thla, Khan Sen Sok, Phnom Penh, Cambodia.

Tel: (855) 23 868 885 / 23 868 886

E-mail: info@lnlcambodia.com Website: www.lnlcambodia.com

Container- AAP

Internal Volume: 371 cu. ft, 10.51 mc

Tare Weight: 220 kg

Maximum Gross Weight: 4.626 kg

Loadable Aircraft Type: 747, 747F, 777, Airbus

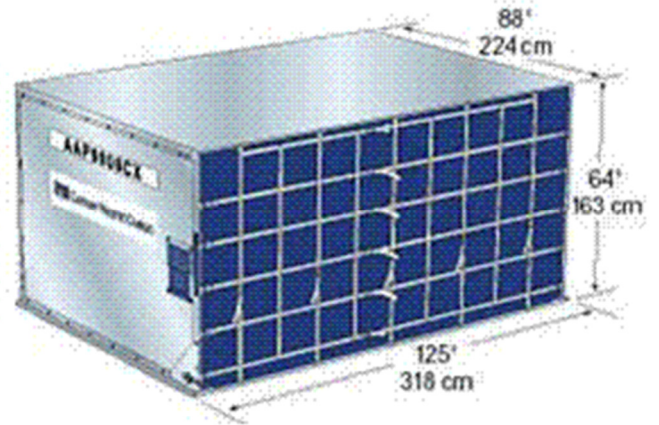

Container- ALF

Internal Volume: 310cu ft, 8.78 mc

Tare Weight: 157 kg

Maximum Gross Weight: 3,175 kg

Loadable Aircraft Type: 747, 747F, 777, Airbus

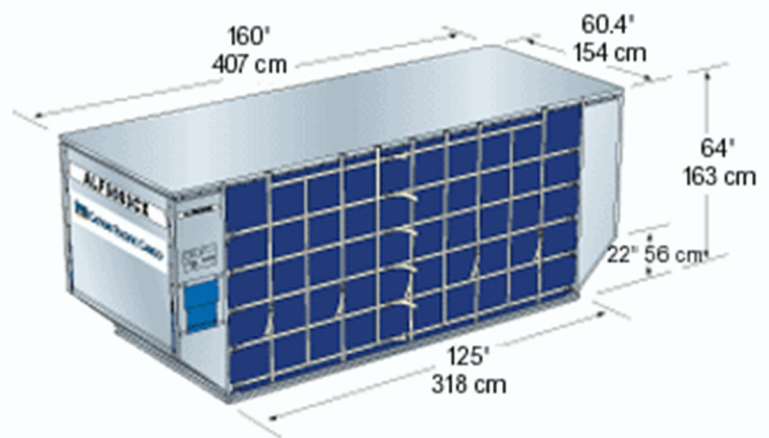

Container- AMA

Internal Volume: 621 cu, ft. 17.58mc

Tare Weight: 477kg

Maximum Gross Weight: 6,804 kg

Loadable Aircraft Type: 747F

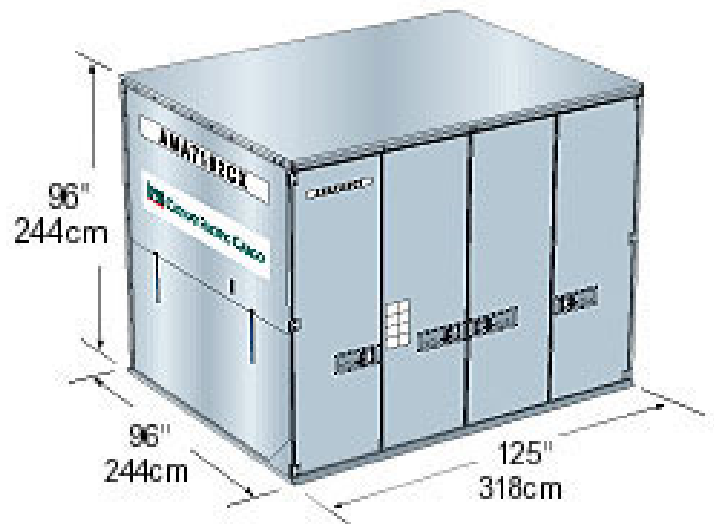



LNL (Cambodia) Co., Ltd.

House No.14, Street No,02A, Sangkat Teuk Thla, Khan Sen Sok, Phnom Penh, Cambodia.

Tel: (855) 23 868 885 / 23 868 886

E-mail: info@lnlcambodia.com Website: www.lnlcambodia.com

Container- AMF

Internal Volume: 516 cu. ft. 14.6mc

Tare Weight: 315 kg

Maximum Gross Weight: 5.035 kg

Loadable Aircraft Type: 747, 747F, 777, Airbus

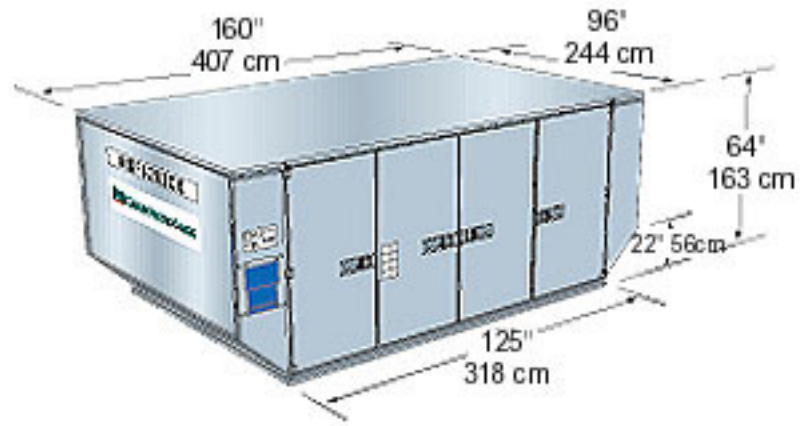

Container- AKE

Internal Volume: 152 cu.ft, 4.3mc

Tare Weight: 73kg/ 100kg

Maximum Gross Weight: 1,588 kg

Loadable Aircraft Type: 747, 747F, 777, Airbus

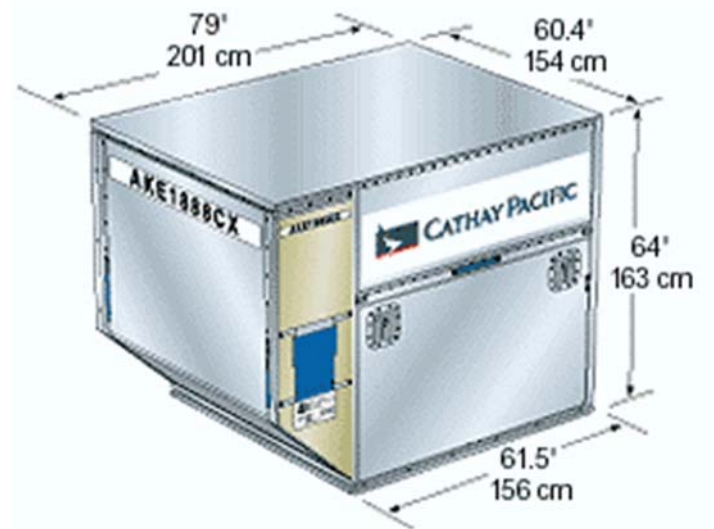



LNL (Cambodia) Co., Ltd.

House No.14, Street No,02A, Sangkat Teuk Thla, Khan Sen Sok, Phnom Penh, Cambodia.

Tel: (855) 23 868 885 / 23 868 886

E-mail: info@lnlcambodia.com Website: www.lnlcambodia.com

20 FT PALLET

IATA ULD Code: PGA 20ft flat pallet with net

Also known as: PGA, PGE, PGF, P7E, P7F, P7G

PSA, PSG, P7A

Classification: M-6

Rate Class: Type 1

Suitable for: B747F, B747Combi

Internal volume: 33.2 cu. m(1174cu. ft)

Maximum gross weight: 11340kg (25000 lb)

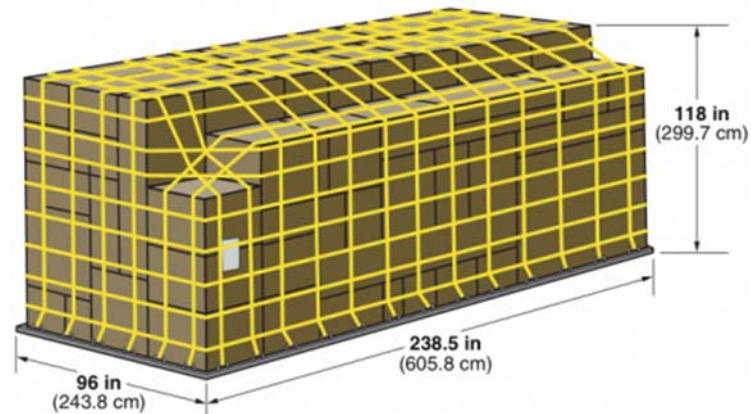

AQ6

IATA ULD Code: AMA Rectangular Container on

P6P Base

Also known as: AMF, AMG, AMK, AMP, AQA, AQD, AQ6

Classification: A-2

Rate Class: Type 2

Suitable for: B747F, B747Combi

Internal volume: 17.5cu. m(618cu. ft)

Maximum gross weight: 6804Kg (15000 lb)

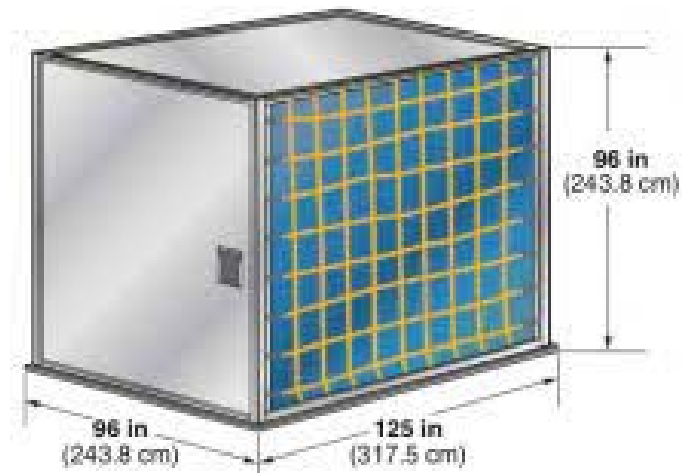

AQ7

IATA ULD Code: AMD Contoured Container on P6P Base

Also known as: AQA, AQ7

Classification: M1H

Rate Class: Type 2H

Suitable for: B747F, B747Combi

Internal volume: 19.9 cu. m(702 cu. ft)

Maximum gross weight: 6800kg (14991 lb)

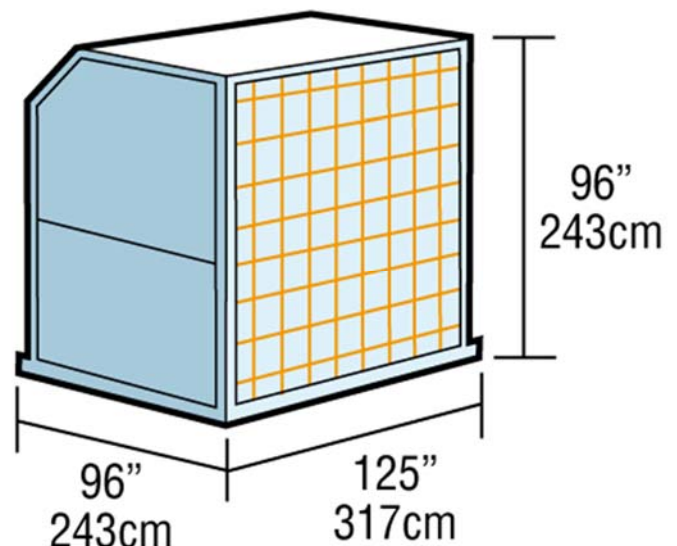



LNL (Cambodia) Co., Ltd.

House No.14, Street No,02A, Sangkat Teuk Thla, Khan Sen Sok, Phnom Penh, Cambodia.

Tel: (855) 23 868 885 / 23 868 886

E-mail: info@lnlcambodia.com Website: www.lnlcambodia.com

96" PALLET

IATA ULD Code: P6P 10ft flat pallet with net

Also known as: p6A, P6C, P6Q, PMA, PMC, PMP, PQP

Classification: LD-9

Rate Class: Type 2BG

Suitable for: A300, A310, A330, A340, B747,

B777, DC-10, MD-11, L1011

Maximum gross weight: 6,804kg (15000 lb)

Can be loaded to 96"(162 cm)

And 118" (300cm) on freighters

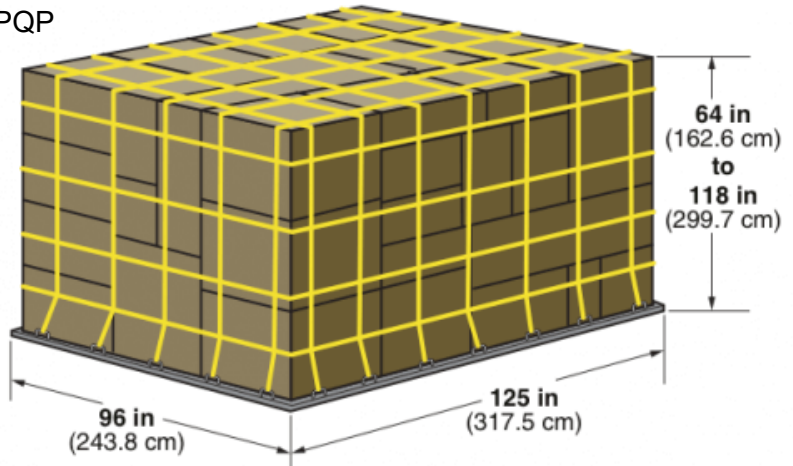

HALF PALLET

IATA ULD Code: PLA half pallet with net

Also known as: PLB, FLA, P9A, P9B, P9R, P9S

Classification: HP

Suitable for: Lower deck: B747, B777

Main Deck: B707F, B727F, B737F

Maximum volume: 7.2cu. m(254 cu. ft)

Maximum gross weight: 3175kg (69.99 lb)

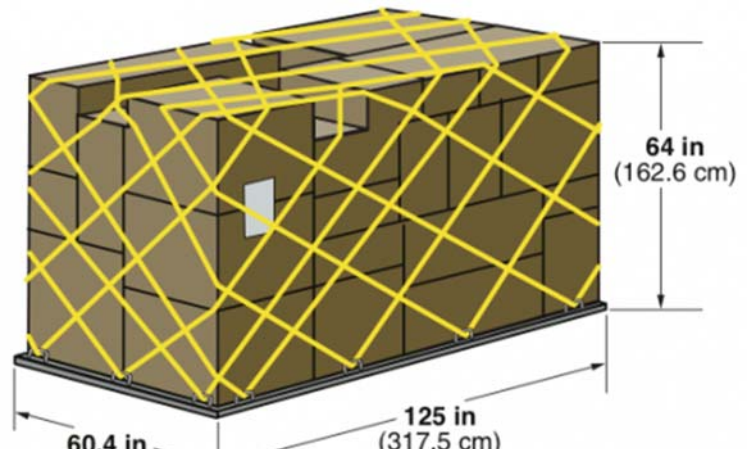

16 FT PALLET

IATA ULD Code: PRA 16ft flat pallet with net

Also known as: PMA, P4A, P4M, PZA

Classification: MDP

Rate Class: Type 1P

Suitable for: B747, B747Combi

Maximum volume: 26.8 cu. m(946cu. ft)

Maximum gross weight: 11300kg (24991 lb)

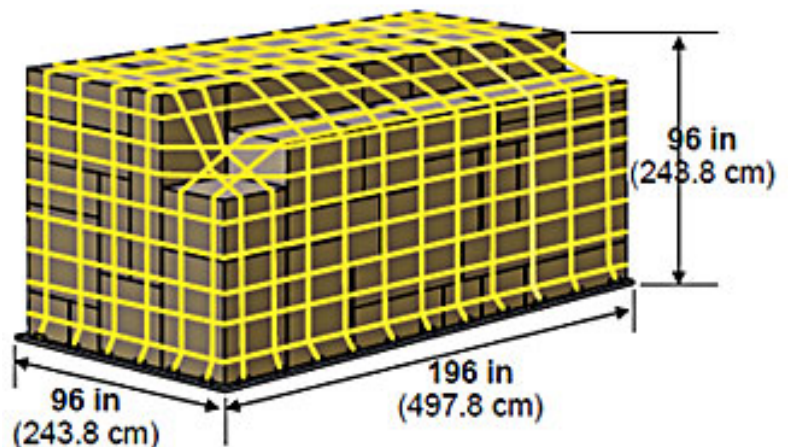



LNL (Cambodia) Co., Ltd.

House No.14, Street No,02A, Sangkat Teuk Thla, Khan Sen Sok, Phnom Penh, Cambodia.

Tel: (855) 23 868 885 / 23 868 886

E-mail: info@lnlcambodia.com Website: www.lnlcambodia.com

LD-7

IATA ULD Code: XAW P1P Pallet with fixed angle wings and met
Classification: LD-7
Rate Class: Type 5
Suitable for: Wide body: All aircraft
Maximum volume with overhang:
14.0 cu. m(494 cu. ft)
Maximum gross weight: 5000kg (11023 lb)

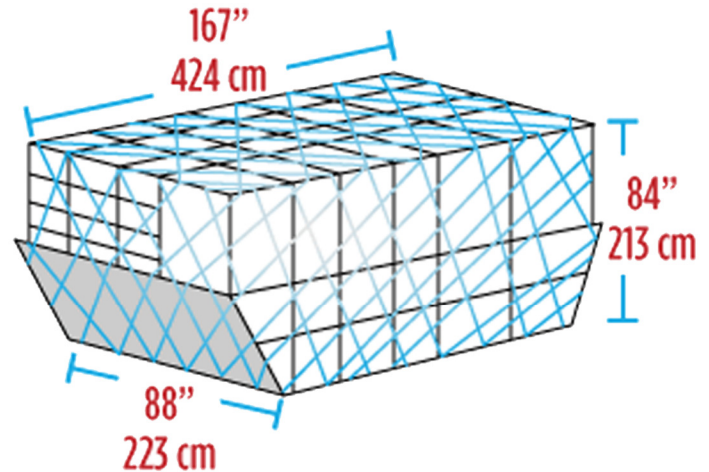

LD-8

IATA ULD Code: DQF
Also known as: ALE, ALN, DLE, DLF, DQP, MQP
Classification: LD-8
Rate Class: Type 6A
Suitable for: B767
Internal volume: 6.85cu. m(242cu. ft)
Maximum gross weight: 2450kg (5401 lb)

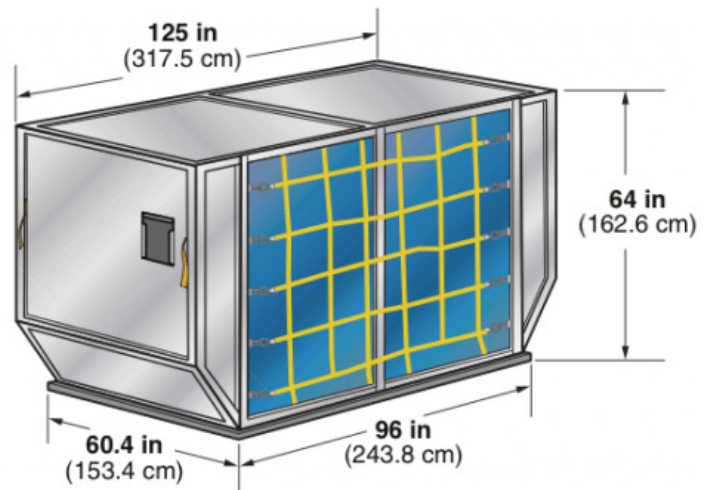

LD-9

IATA ULD Code: AAP Enclosed Pallet on P1P base
Also known as: AA2, XAG, XAV
Forkable: AWC
Classification: LD-9
Rate Class: Type 5
Suitable for: A300, A310, A330, A340, B747, B767, DC-10, MD-11, L1011
Internal volume: 9.1 cu. m(321 cu. ft)
Maximum gross weight:
4624 kg(7000 lb) lower deck
6000 kg(13227 lb) main deck

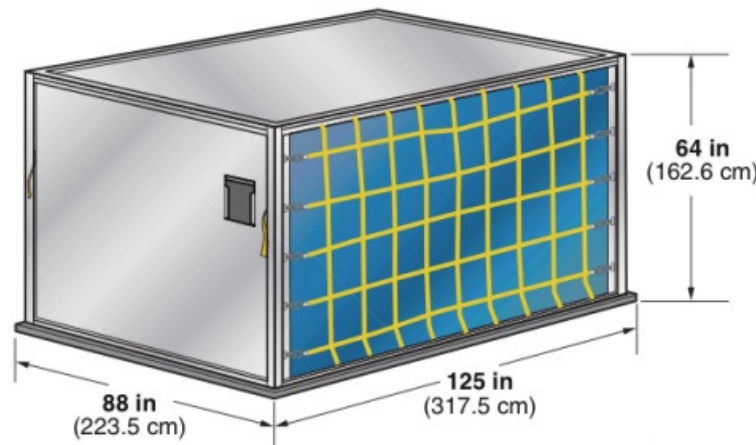



LNL (Cambodia) Co., Ltd.

House No.14, Street No,02A, Sangkat Teuk Thla, Khan Sen Sok, Phnom Penh, Cambodia.

Tel: (855) 23 868 885 / 23 868 886

E-mail: info@lnlcambodia.com Website: www.lnlcambodia.com

Insulated LD-3

IATA ULD Code: RKN

Classification: LD-3

Rate Class: Type 8

Suitable for: A300, A310, A330, A340, B747

B767, B777, DC-10, MD11, L1011

Internal volume: 3.0 cu.m(109 cu.ft)

Maximum gross weight: 1588kg (3500 lb)

Temperature Control Range: -20C to+20C

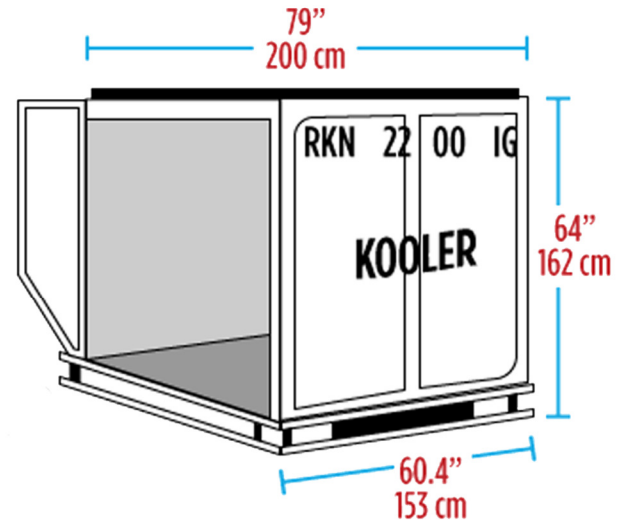

LD-4

IATA ULD Code: ALP Rectangular Container

Also known as: ALD, AWD, AWZ, DLP

Forkable: ALB, ALC, AWB, AWC

Classification: LD-4

Rate Class: Type 8

Suitable for: B767, B777

Internal volume: 5.7cu.m(201 cu. Ft)

Maximum gross weight: 2449kg (5399 lb)

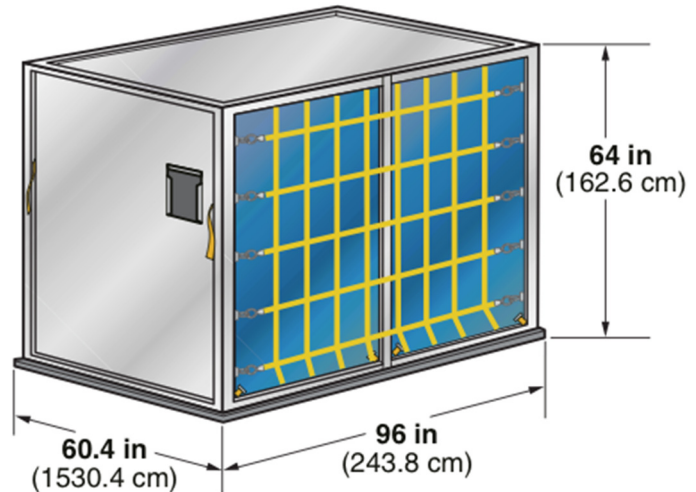

LD-6

IATA ULD Code: ALF Contoured Container

Also known as: AWD, AWF

Forkable: AWC

Classification: LD-6

Rate Class: Type 6W

Suitable for: A300, A310, A330, A340, B747, B777,

DC-10, MD-11, L1011

Internal volume: 8.0 cu.m (314cu. ft)

Maximum gross weight: 3175 kg(7000 lb)

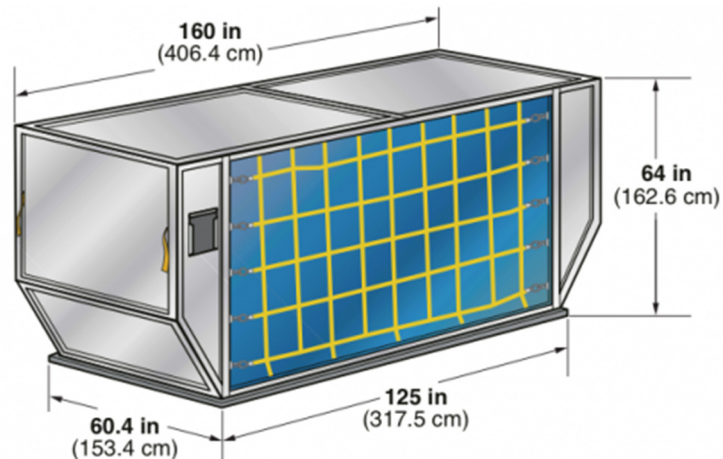



LNL (Cambodia) Co., Ltd.

House No.14, Street No,02A, Sangkat Teuk Thla, Khan Sen Sok, Phnom Penh, Cambodia.

Tel: (855) 23 868 885 / 23 868 886

E-mail: info@lnlcambodia.com Website: www.lnlcambodia.com

LD-1

IATA ULD Code: AKC Contoured Container

Also known as: AVC, AVD, AVK, AVJ

Forkable: AVY

Classification: LD-1

Rate Class: Type 8D

Suitable for: B747, B767, B777, MD-11

Internal volume: 4.8 cu. M(169.5cu. ft)

Maximum gross weight: 1588kg (3501 lb)

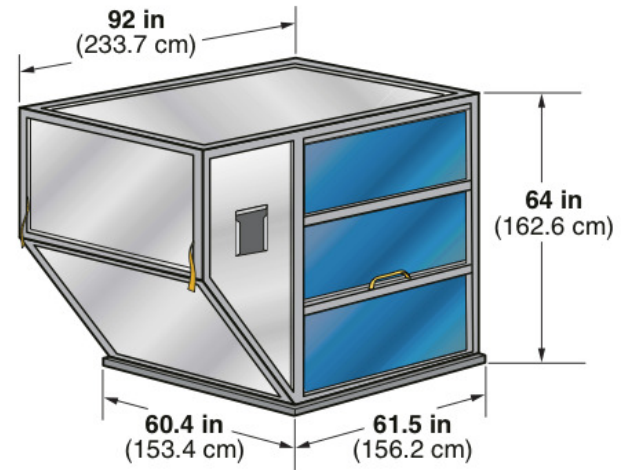

LD-2

IATA ULD Code: DPE Contoured Container

Also known as: APA, DPA

Forkable: DPN

Classification: LD-2

Rate Class: Type 8D

Suitable for: B767

Internal volume: 3.4 cu.m(120cu.ft)

Maximum gross weight: 1225kg (200 lb)

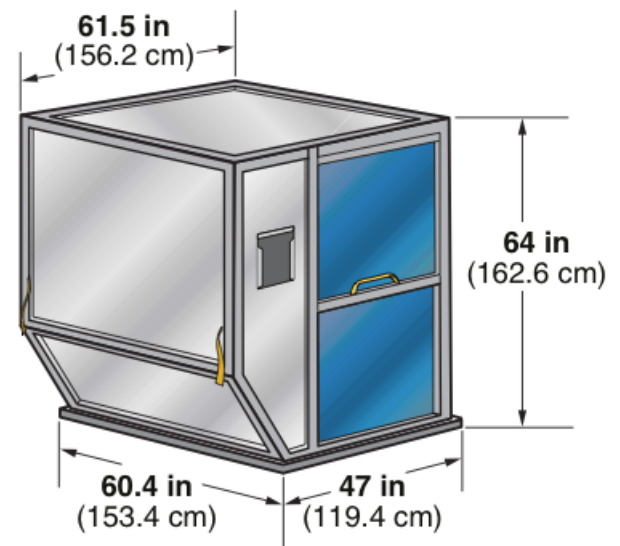

LD-3

IATA ULD Code: AKE Contoured Container

Also known as: AKE, AVA, AVB, AVC, AVK, DVA, DVE, DVP, XKS, XKG

Forkable: AKN, AVN, DKN, DVN, XKN

Classification: LD-3

Rate Class: Type 8

Suitable for: A300, A310, A330, A340, B747, B767, B777,

DC-10, MD-11, L1011

Internal volume: 3.4 cu.m(120cu.ft)

Maximum gross weight: 1225kg (200 lb)

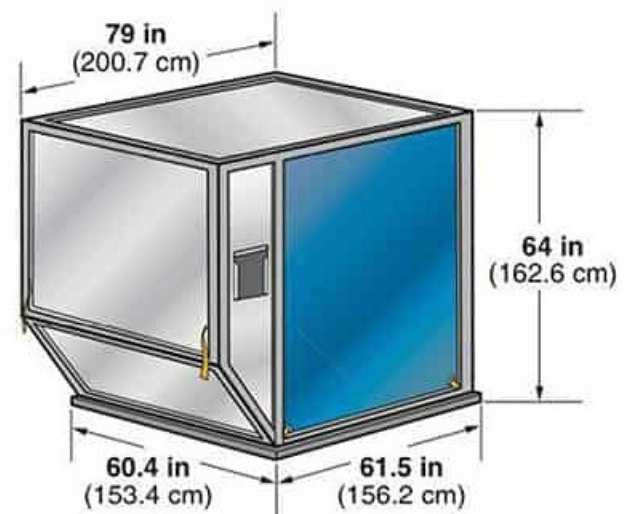



LNL (Cambodia) Co., Ltd.

House No.14, Street No,02A, Sangkat Teuk Thla, Khan Sen Sok, Phnom Penh, Cambodia.

Tel: (855) 23 868 885 / 23 868 886

E-mail: info@lnlcambodia.com Website: www.lnlcambodia.com

Pallet – PGA

Internal Volume: Base 96" x 238.5" Height 96"

(Q6 Contour), 118"(Q7 Contour)

Tare Weight: 565 kg

Maximum Gross Weight: 13,608 kg

Loadable Aircraft Type: 747F,

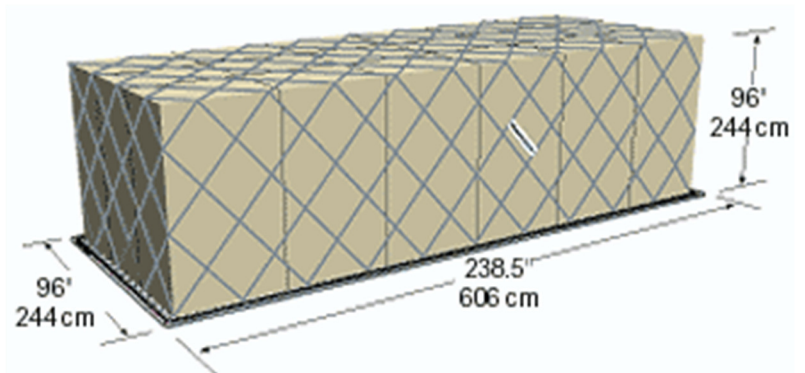

Pallet - PLA

Internal Volume: Base 60.4" x 125" Height 64"

Tare Weight: 103 kg

Maximum Gross Weight: 3,175 kg

Loadable Aircraft Type: 747, 747F, 777, Airbus

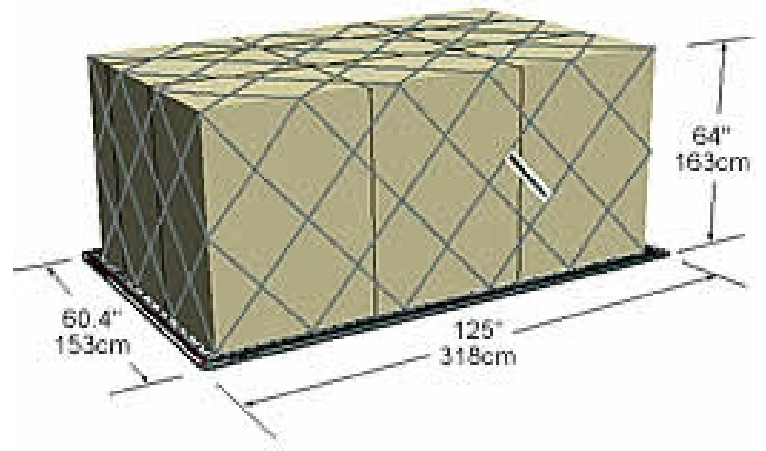

Pallet – PMC, PQP, P6P

Internal Volume: Base 96" x 125" Height 64"(Passenger Flight),

96" (Q6 Contour), 118" (Q7 Contour)

Tare Weight: 120 kg

Maximum Gross Weight: 5,035 kg (LD), 6,804 kg (MD)

Loadable Aircraft Type: 747, 747F, 777, Airbus

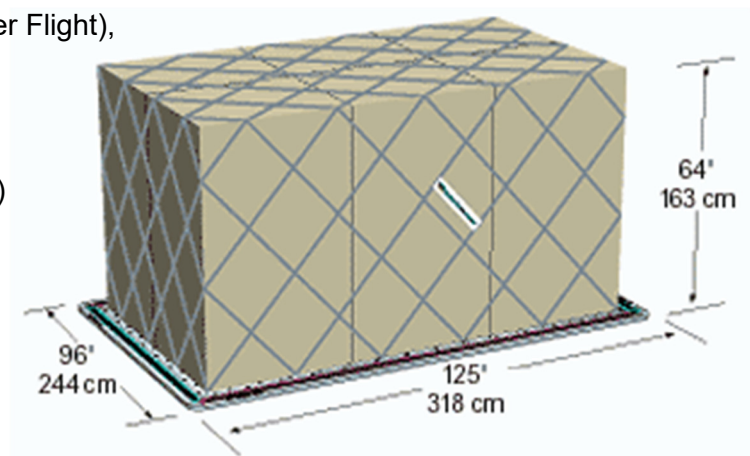



LNL (Cambodia) Co., Ltd.

House No.14, Street No,02A, Sangkat Teuk Thla, Khan Sen Sok, Phnom Penh, Cambodia.

Tel: (855) 23 868 885 / 23 868 886

E-mail: info@lnlcambodia.com Website: www.lnlcambodia.com

Pallet – P1P.- PAG

Internal Volume: Base 88" x 125" Height 64"(Passenger Flight)
, 96"(Q6 Contour), 118"(Q7 Contour)

Tare Weight: 114 kg

Maximum Gross Weight: 4,626 kg(LD)

Loadable Aircraft Type: 747, 747F, 777, Airbus

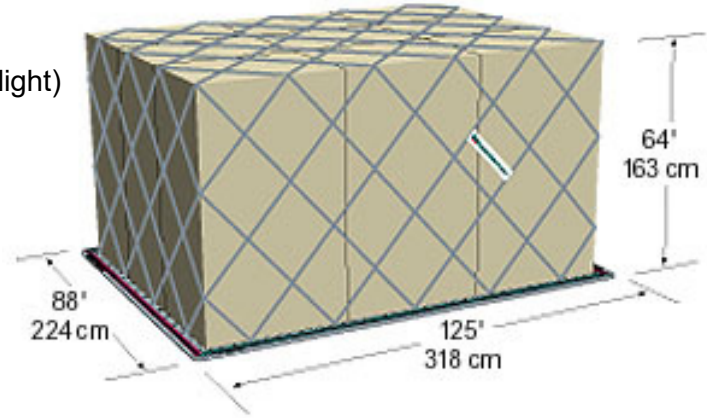

Pallet - PEB

Internal Volume: Base 53" x 88" Height 84"

Tare Weight: 55 kg

Maximum Gross Weight: 1,800 kg(B-HIH – 1,300 kg)

Loadable Aircraft Type: 747F

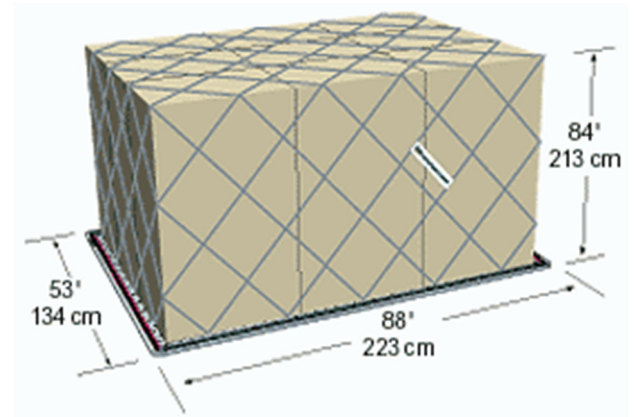

Stacking Guide

Use CX Master labels for clear, quick identification

Correct

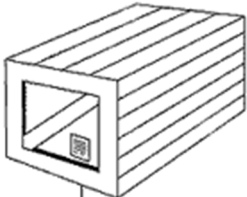

Air Waybill Label
(Destination and Number)

Incorrect

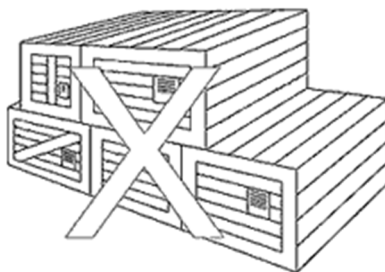

Correct

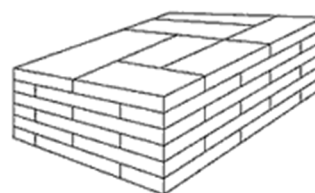

Interlocking layers

Incorrect

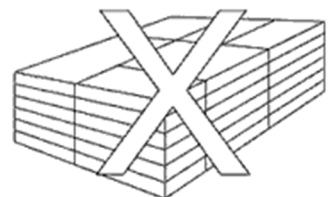

Stacking boxed on pallets



LNL (Cambodia) Co., Ltd.

House No.14, Street No,02A, Sangkat Teuk Thla, Khan Sen Sok, Phnom Penh, Cambodia.

Tel: (855) 23 868 885 / 23 868 886

E-mail: info@lnlcambodia.com Website: www.lnlcambodia.com

M-6

IATA ULD Code: PGA 20ft Box Container

Also known as: ASE

Classification: M-6

Rate Class: Type 1

Suitable for: B747F, B747Combi

Internal volume: 33.2 cu. m(1165cu. ft)

Maximum gross weight: 11340kg (25000 lb)

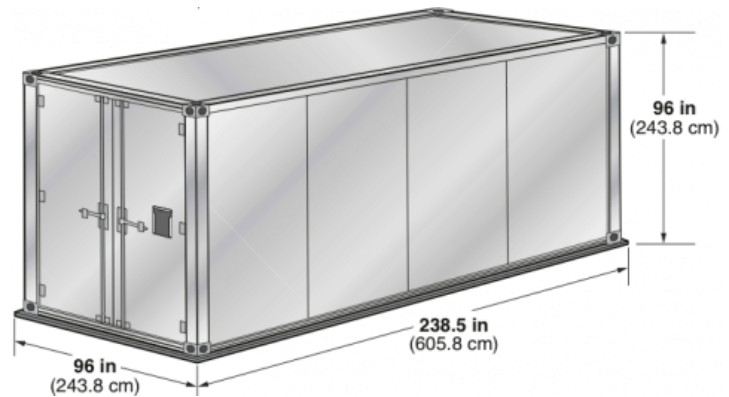

LD-26

IATA ULD Code: AAF

Classification: LD-26

Suitable for: B747F, B777, DC-10

Maximum gross weight:

747/DC-10: 6033kg(13300 lb)

777/DC-10: 4626kg(10501 lb)

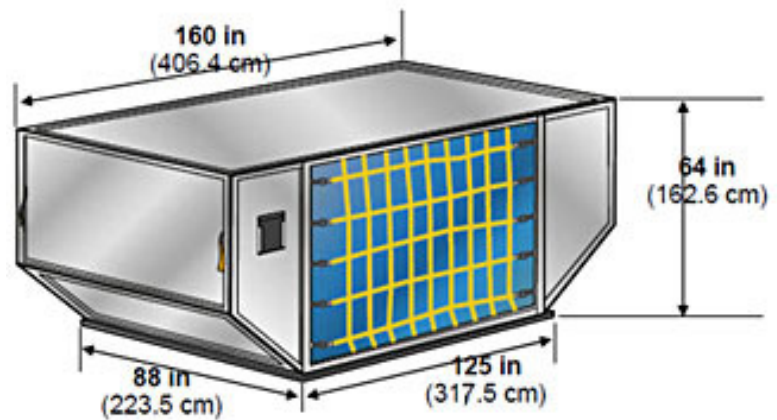

LD-29

IATA ULD Code: AAU Contoured Container on P1P base

Classification: LD-29

Rate Class: Type 5

Suitable for: B747

Internal volume: 14.2 cu. m(501cu. ft)

Maximum gross weight: 6033kg (13300 lb)

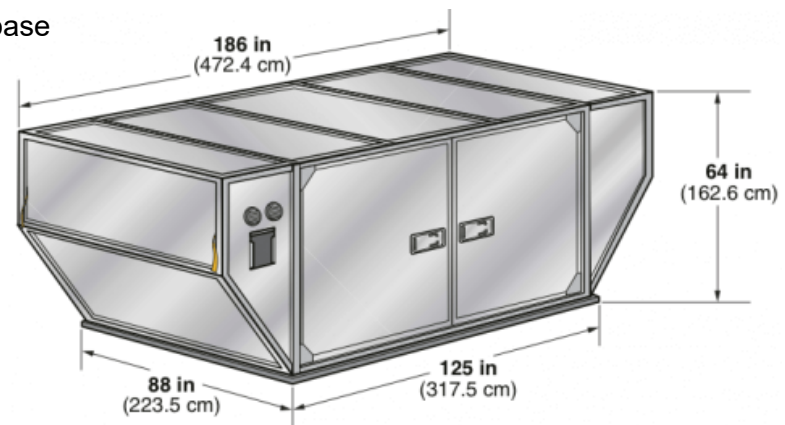



LNL (Cambodia) Co., Ltd.

House No.14, Street No,02A, Sangkat Teuk Thla, Khan Sen Sok, Phnom Penh, Cambodia.

Tel: (855) 23 868 885 / 23 868 886

E-mail: info@lnlcambodia.com Website: www.lnlcambodia.com

LD-11

IATA ULD Code: ALP Rectangular Container

Also known as: ALD, AW2, AWB, AWD, AWZ, DLP, DWB, MWB

Refrigerated version: RWB, RWD, RWZ

Classification: LD-11

Rate Class: Type 6

Suitable for: A300, A310, A330, A340, B747, B777, DC-10, MD-11, L1011

Internal volume: 7.2cu. m(253 cu. ft)

Maximum gross weight: 3176kg (7002 lb lb)

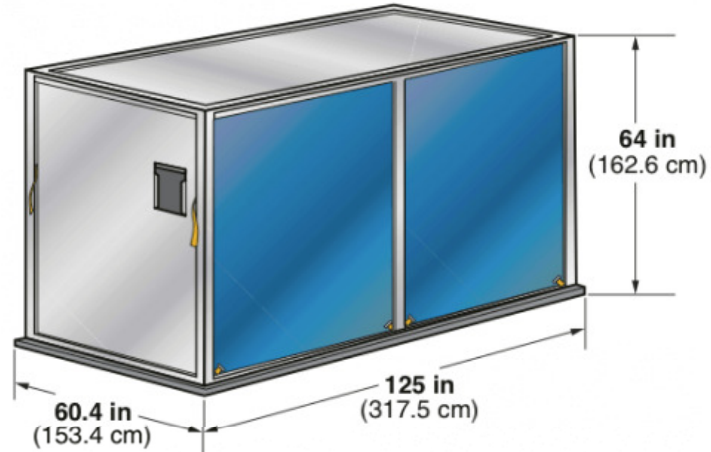

A-2

IATA ULD Code: DDA

Classification: A-2

Suitable for: B747, B747F, DC8, DC10, A300/F

Internal volume: 12.6cu. m(444 cu. ft)

Maximum gross weight: 6033kg (13300 lb)

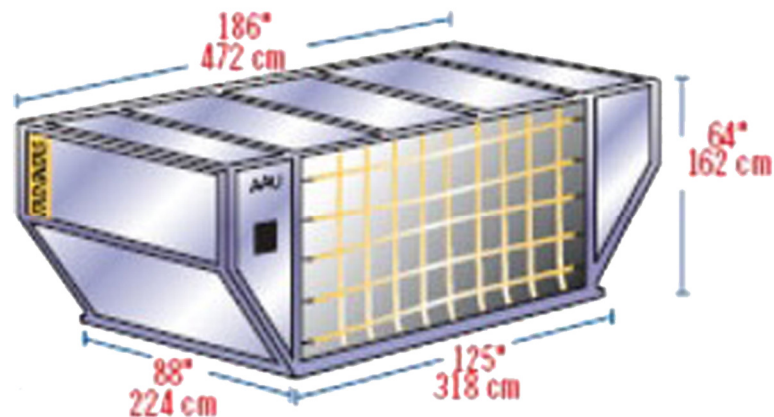

88" Pallet

IATA ULD Code: P1P

Classification: 88" Pallet with net

Suitable for: B747, B767, B777, DC-10

Maximum volume: 11.9 cu. m.(420 cu. ft)

767: 5103kg (11227 lb)

777/DC-10: 4626 kg(10501 lb)

Can be loaded to 96"(162 cm) and 118" (300cm)

On freighters

